

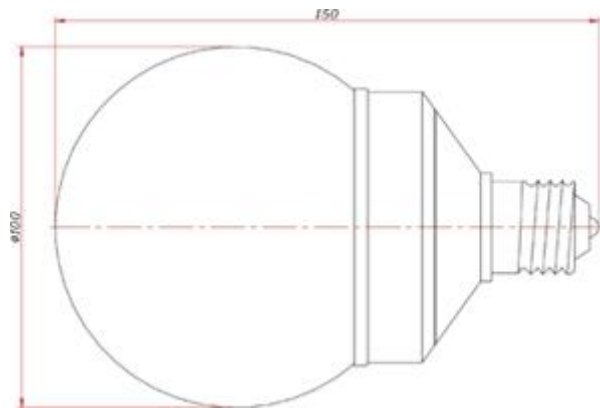

100 LED Bulb Lamp Specification

Model:	TMT-B-100-W84-220
	TMT-B-100-R84-220
	TMT-B-100-G84-220
	TMT-B-100-B84-220
Dimension:	φ100*150MM
Led Number:	84
Protective levels:	
Power	6W
N.W./G.W.	80g/125g

LED bulb lamp structure:



LED bulb lamp features:

E27 screw base.

Voltage: AC110V/220V.

Power: 1-4W

Intensity: 35-600mcd/squaremeter

Working temperature: -40°C-- +80°C

Structure: PC or glass

Colors: Colors Jump changing, gradual changing, synchronous changing, program controlling.

Available for advertisement, building gate, building structure and house decoration.